



Acct# 1018326

Wilson Tool International, Inc
12912 Farnham Avenue
WHITE BEAR LAKE, MN 55110
US

Ship Via: UPS Ground
SO: 1664482-30
Prod Ord: 11104432
P.O. Number 86122

Sold To Triax Metal Products LLC
1880 SW Merlo Drive
BEAVERTON OR 97003
US

Ship To Triax Metal Products LLC
1880 SW Merlo Drive
BEAVERTON OR 97003
US

Contact: Shaun Fitch Phone: 503-649-9500-140 Fax: 503-649-1888 Email: shaun@triaxmetal.com

Order Date 03/19/2019	Target Ship Date 03/28/2019	Question Contact Craig Roy-Nyline	Instructions
QTY: 1 S190 Special Model			
BACK TO BACK LOUVER 2.974 LONG			
STATION: E STATION (4-1/2)	RELIEF: NO RELIEF	KEYING: STANDARD	MATL: COLD ROLL
STYLE: DETERMINE	AUTO INDX: NO		MATL THK: 0.0480 in
MACHINE: AMADA	AUTO LOAD: NO	DIRECTION: FORM UP	
MODEL: VIPROS 358	HIGH FORM: NO		COATING: OPTIMA
STYLE: THICK			
Item 1 - FULL ASSEMBLY (SET)			

TOOL #2 OF 2
RUN WITH S.O.# 1664482-10

NO LENGTH TAG!
ADJUST UPPER UNIT LENGTH TO: 8.044

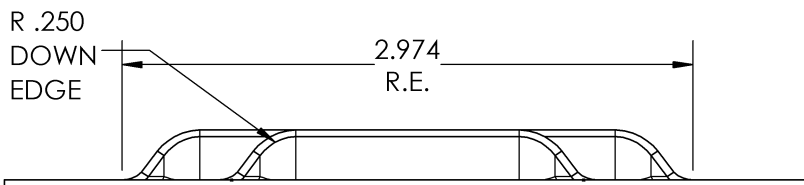
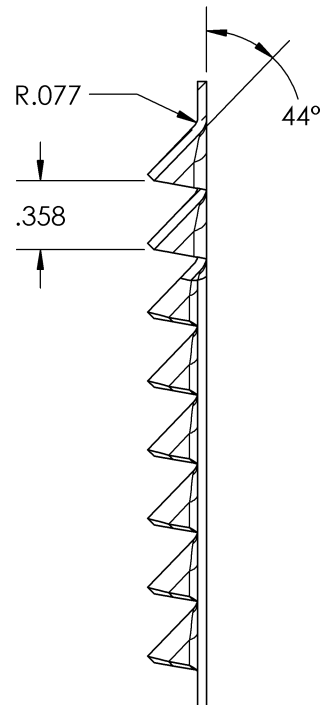
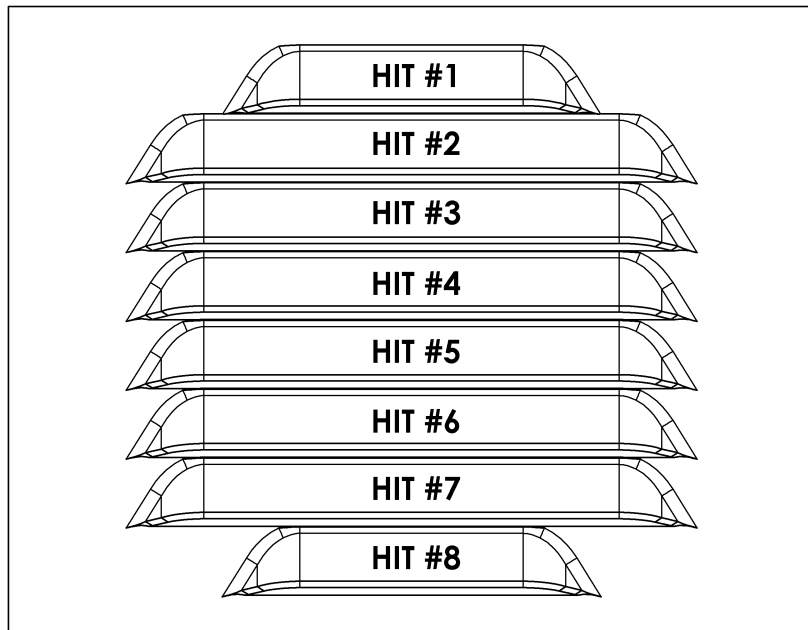

*** MODIFIED PUNCH BODY**

JCC
PROD# 11104432

These items are controlled by the U.S. Government and authorized for export only to the country of ultimate destination for use by the ultimate consignee or end-user(s) herein identified. They may not be resold, transferred, or otherwise disposed of, to any other country or to any person other than the authorized ultimate consignee or end-user(s), either in their original form or after being incorporated into other items, without first obtaining approval from the U.S. government or as otherwise authorized by U.S. law and regulations.