

# 1.1/4" THICK DOUBLE KNOCKOUT TOOL

TOOL NUMBER	CUSTOMER NAME	DWG BY	DATE	MATERIAL INFO.
A2024020152	TRIAX METAL	BDB	5/5/98	.060 CRS

ET# 98R29496  
DUE DATE 5/13/98

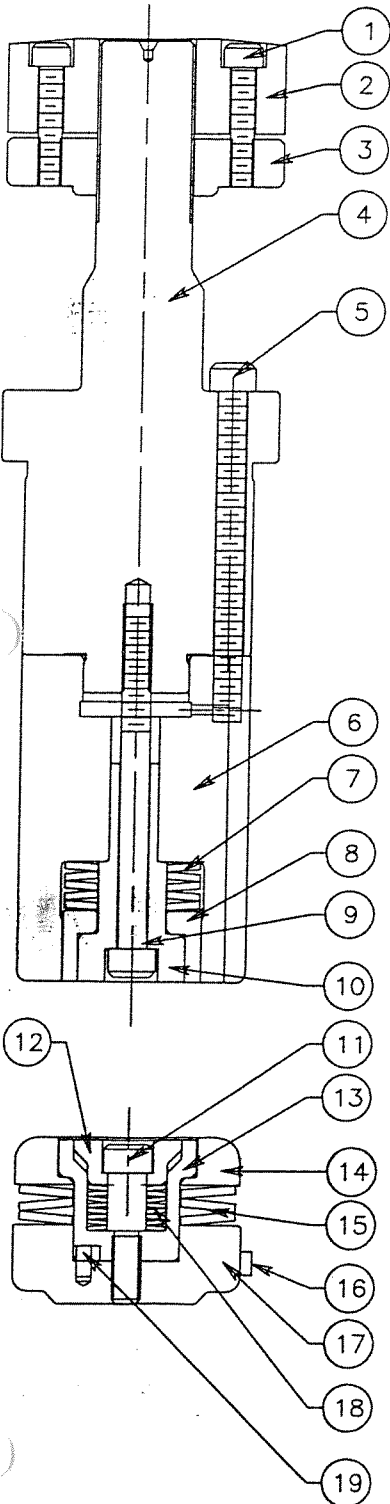
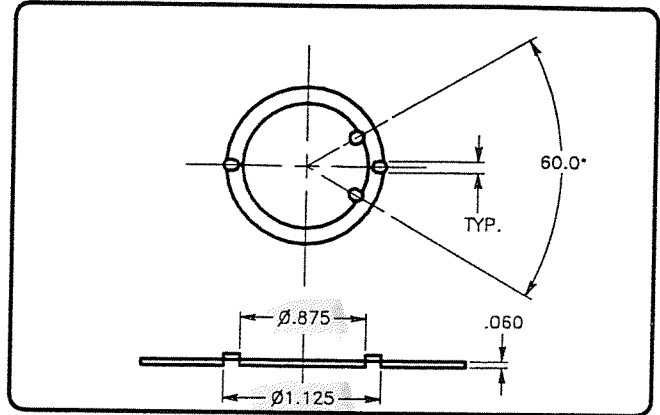

NO.	PART NUMBER	QTY	DESCRIPTION
1	00105025	4	S.H.C.S. M5X25
2	5518200	1	UPPER PUNCH HEAD 1
3	5516431	1	LOWER PUNCH HEAD
4	8800086	1	PUNCH DRIVER (ALTER)
5	00106070	4	S.H.C.S. M6X70
6	9100217	1	PUNCH HOLDER
7	01473	5	BELLVILLE SPRING $\phi 28-\phi 14.2-1.5$
8	9600410	1	EJECTOR PIN
9	00106070	1	S.H.C.S. M6X70
10	9600411	1	PUNCH CHIP
11	01008020	1	ALTER ST08X20
12	9600412	1	DIE EJECTOR
13	9600413	1	DIE BODY
14	9600414	1	EJECTOR PLATE
15	01475	3	BELLVILLE SPRING $\phi 45-\phi 22.4-1.75$
16	5550138	1	KEY (STD)
17	9600415	1	DIE HOLDER
18	01474	8	BELLVILLE SPRING $\phi 16-\phi 8.2-0.9$
19	02830	1	SPRING ROLL PIN $\phi 1/8" \times 1/4"$