

1.1/4" THICK SHAPE EMBOSS A TYPE P/CHIP A TYPE DIE

TOOL NUMBER	CUSTOMER NAME	DWG BY	DATE	MATERIAL INFO.
A1084010488	TRIAx METAL	BDB	1/26/98	.075 EL/GALV.

ET# 98M00041-2/3
DUE DATE 1/30/98

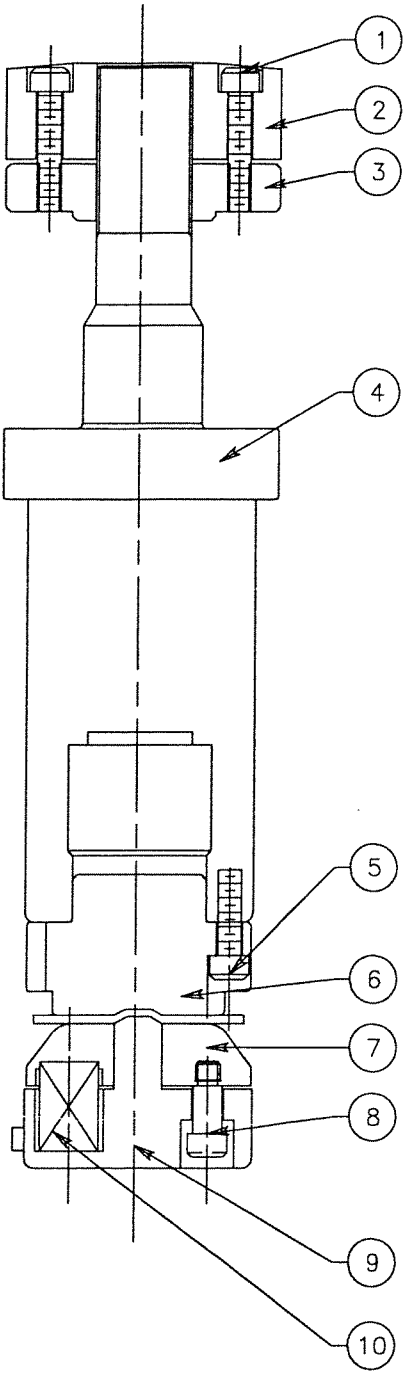
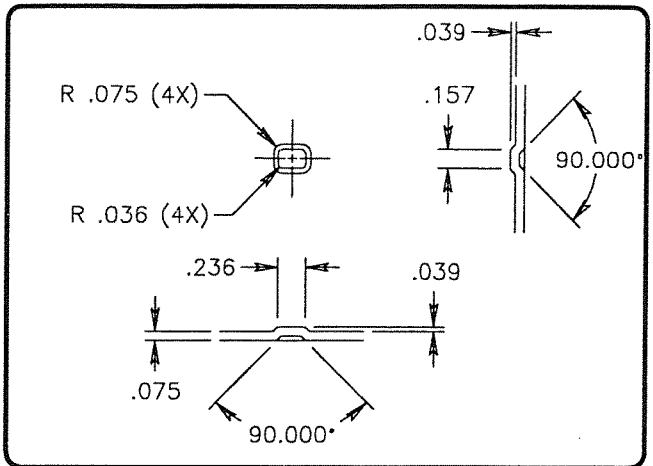

NO.	PART NUMBER	QTY	DESCRIPTION	SHEET #
1	00105025	4	S.H.C.S. M5X25	
2	5518200	1	UPPER PUNCH HEAD 1	
3	5516431	1	LOWER PUNCH HEAD	
4	8800085	1	PUNCH HOLDER	
5	00105018	4	S.H.C.S. M5X18	
6	8800081	1	PUNCH CHIP TYPE A (SHAPE)	
7	8700043	1	EJECTOR PLATE TYPE A	
8	01006010	3	STO 6X10	
9	9000189	1	DIE BODY TYPE A (SHAPE)	
10	01312025	3	COIL SPRING SWM 12-25	