



BIN NUMBER
0368-2

UPS SHIPPER NO. MN 5-65-685
SO: 623825-20

ACCOUNT NO. 0001018326

SOLD TO Triax Metal Prod Inc
1880 SW Merlo Drive
BEAVERTON OR 97006
US

SHIP TO Triax Metal Prod Inc
1880 SW Merlo Drive
BEAVERTON OR 97006
US



PROD. ORDER # 557-5263
QNC # 575263

P.O. NUMBER 66499

1215

W.T. NUMBER 623825-20	ORDER DATE 09/04/2008	TARGET SHIP DATE 09/15/2008	CUSTOMER CONTACT Shaun Fitch	CUSTOMER PHONE and FAX PH: 503-649-9500 FAX: 503-649-1888	QUESTIONS CONTACT Bruce Dibbern	TERMS WT10
SALES NO. A0022	INSTRUCTIONS		SHIP VIA UPS1			

C STN THICK SERIES 90 ABS 2 THICK CLUSTER
INSERT STYLE SHAPE CLUSTER TOOL *OPTIMA*

ITEM	QUANTITY	CLEARANCE	CATALOG NUMBER: 13438	ASSEMBLY NUMBER:	SHAPE: CLUST
1	4				
INSERT					

Clust Cell

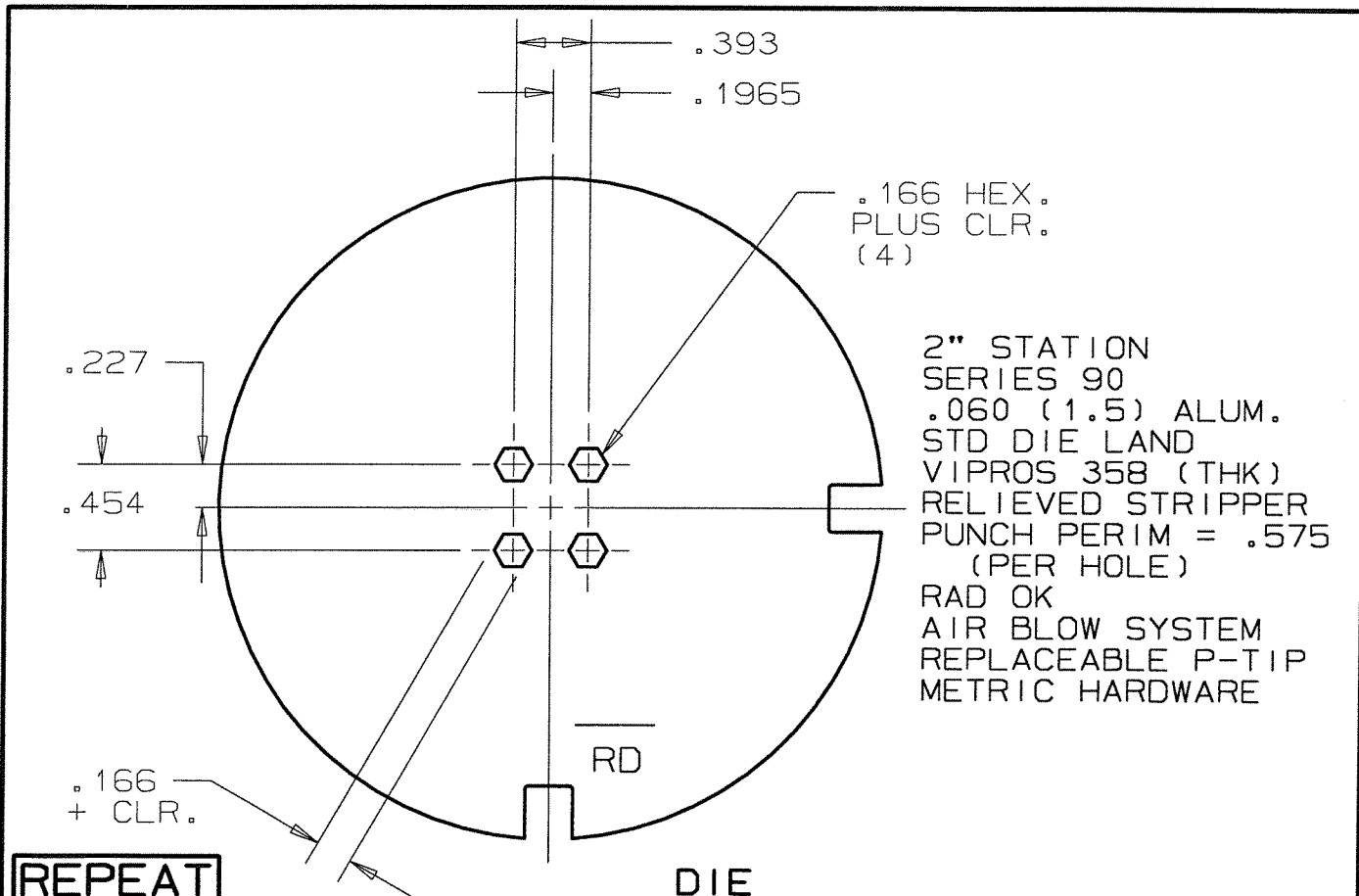

2" STATION
SERIES 90
.060 (1.5) ALUM.
STD DIE LAND
VIPROS 358 (THK)
RELIEVED STRIPPER
PUNCH PERIM = .575
(PER HOLE)
RAD OK
AIR BLOW SYSTEM
REPLACEABLE P-TIP
METRIC HARDWARE

REPEAT
JNH 9-2008

DESIGNER: JNH
557-5262

557-5263

Licensed under U.S. Patent No. 4,977,804 and corresponding foreign patents and patent applications, and authorized for use only on punch press machines manufactured by, for, or under license from Amada Company, Ltd.

PUNCHING LIST