

# S114\_BRIDGE\_LANCE\_UP

TOOL NUMBER	CUSTOMER NAME	DWG BY	DATE	MATERIAL INFO
S114403-0068	TRIAx METAL	RF	1/27/98	GALV

# 98M00041-3/3 DUE: 1/30/98

SCALE 0.333

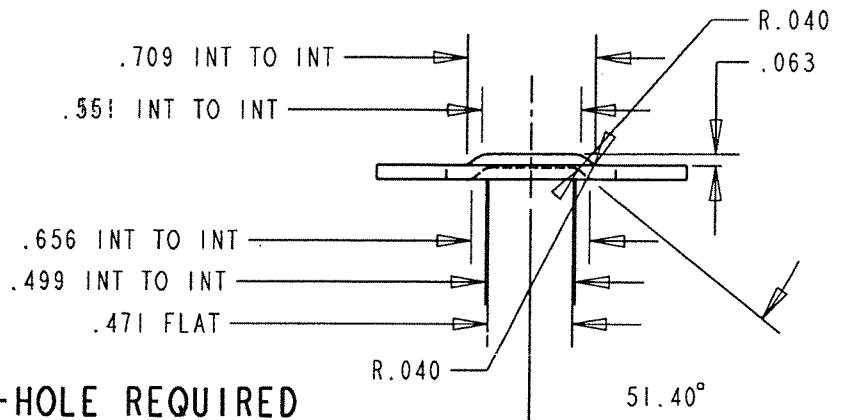
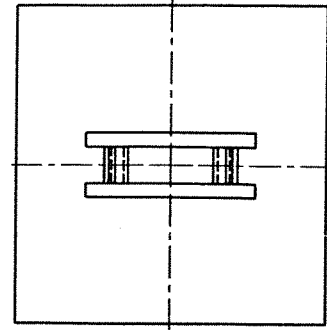
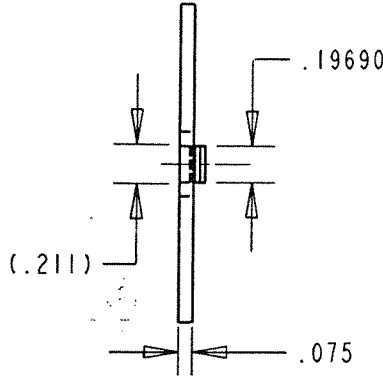
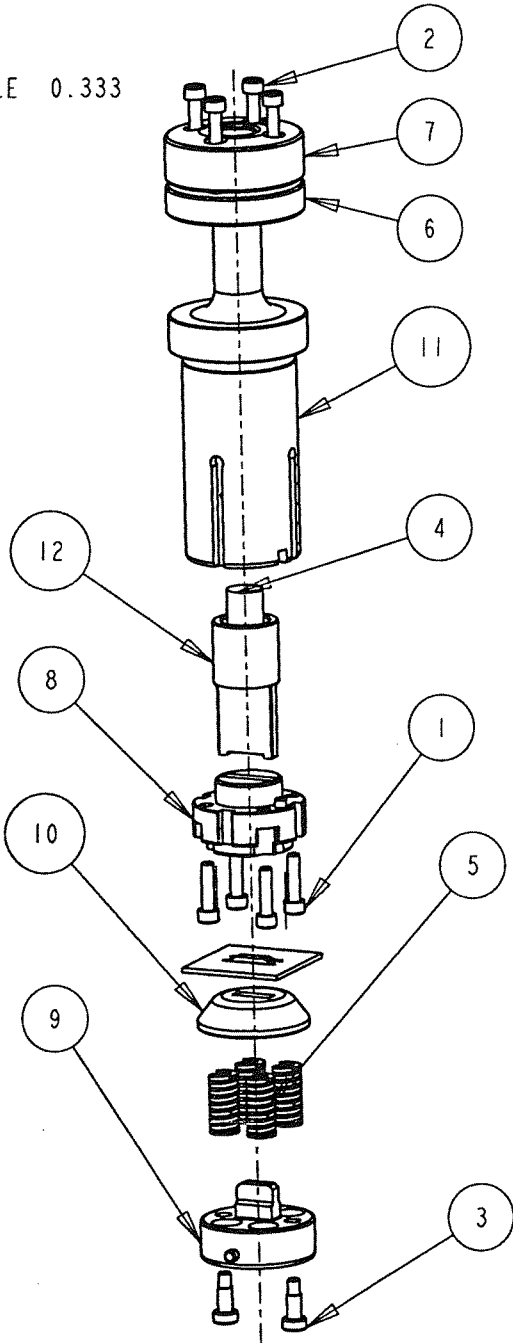

PRE-HOLE REQUIRED

NO.	PART NUMBER	QTY		DESCRIPTION
		SET QTY	PART(S) QTY	
		1		COMPLETE SET(S)
1	00705020	4	0	S.H.C.S. 5MM X 20
2	00105025	4	0	S.H.C.S. 5MM X 25
3	01006010	2	0	6MM X 10 STRIPPER BOLT
4	01215026	1	0	15MM X 26 URETHANE SPRING
5	01312025	4	0	SWM 12MM X 25 COIL SPRING
6	5516431	1	0	UPPER PUNCH HEAD
7	5518200	1	0	UPPER PUNCH HEAD I
8	8800081	1	0	PUNCH CHIP A (SHAPE)
9	8800083	1	0	DIE BODY TYPE "D"
10	8800084	1	0	EJECTOR PLATE TYPE "D"
11	8800085	1	0	PUNCH HOLDER (SHAPED)
12	9000198	1	0	EJECTOR PIN

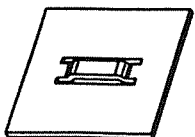

SCALE 0.500