



Wilson Tool International, Inc
 12912 Farnham Avenue
 WHITE BEAR LAKE, MN 55110
 US

Ship Via: UPS 2nd Day Air
 SO: 1844465-10
 Prod Ord: 11917408
 P.O. Number 86379

Acct# 1018326

Sold To Triax Metal Products LLC
 1880 Southwest Merlo Drive
 BEAVERTON OR 97003
 US

Ship To Triax Metal Products LLC
 1880 Southwest Merlo Drive
 BEAVERTON OR 97003
 US

Contact: Shaun Fitch Phone: 503-649-9500-140 Fax: 503-649-1888 Email: shaun@triaxmetal.com

Order Date	Target Ship Date	Question Contact	Instructions
03/26/2021	04/05/2021	Jon Vining	
QTY: 1 12742 1-1/4 Thick Form Only Shape Form-Up			
FORM ONLY BRIDGE PO 86379.STP			
STATION: B STATION (1-1/4)	RELIEF: NO RELIEF	KEYING: STANDARD	MATL: ALUMINIUM
	AUTO INDX: NO		MATL THK: 0.0500 in
MACHINE: AMADA			
MODEL: VIPROS 358			COATING: NO COATING
Item 1 - FULL SET			

* THE APPROXIMATE ADJUSTED PUNCH LENGTH IS : 8.020

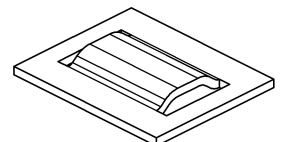
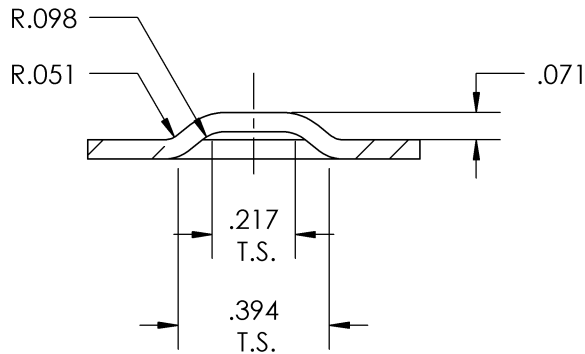
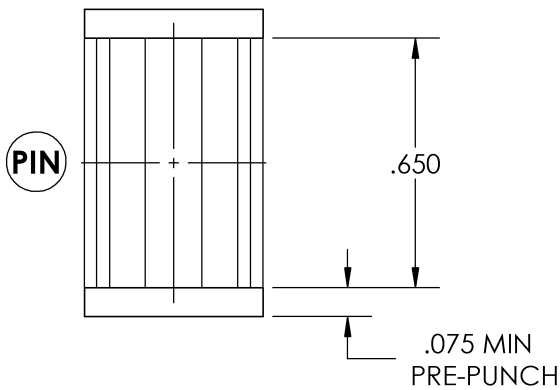

SRJ
 PROD# 11917408

These items are controlled by the U.S. Government and authorized for export only to the country of ultimate destination for use by the ultimate consignee or end-user(s) herein identified. They may not be resold, transferred, or otherwise disposed of, to any other country or to any person other than the authorized ultimate consignee or end-user(s), either in their original form or after being incorporated into other items, without first obtaining approval from the U.S. government or as otherwise authorized by U.S. law and regulations.