



Acct# 1018326

Wilson Tool
12912 Farnham Avenue
WHITE BEAR LAKE, MN 55110
US

Ship Via:	UPS 2nd Day Air
SO:	1229875-50
Prod Ord:	9058482
P.O. Number	83369
Payment Terms	Net due in 10 days

Sold To Triax Metal Products LLC
1880 SW Merlo Drive
CharBEAVERTON OR 97006
US

Ship To Triax Metal Products LLC
1880 SW Merlo Drive
BEAVERTON OR 97006
US

Contact: Shaun Fitch Phone: 503-649-9500-140 Fax: 503-649-1888 Email: shaun@triaxmetal.com

Order Date 01/21/2015	Target Ship Date 01/27/2015	Question Contact Mark Wolkstorfer	Instructions DRAWN IN 1.2 MM USING .050
--------------------------	--------------------------------	--------------------------------------	--

QTY: 1 2244 Thick Single Bridge Lance & Form Up B Station

BRIDGE 441-2827STP

STATION: B STATION (1-1/4)	RELIEF: NO RELIEF	KEYING: STANDARD	MATL: ALUMINUM
STYLE: DETERMINE	AUTO INDX: NO		MATL THK: 0.0500 in
MACHINE: AMADA	AL/HF: NO		MIN MATL: 0.0500 in
MODEL: VIPROS 358			COATING: NO COATING

Item 1 - FULL SET, CLR: 0.0050 in

* THE APPROXIMATE ADJUSTED PUNCH LENGTH IS : 8.020

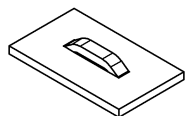
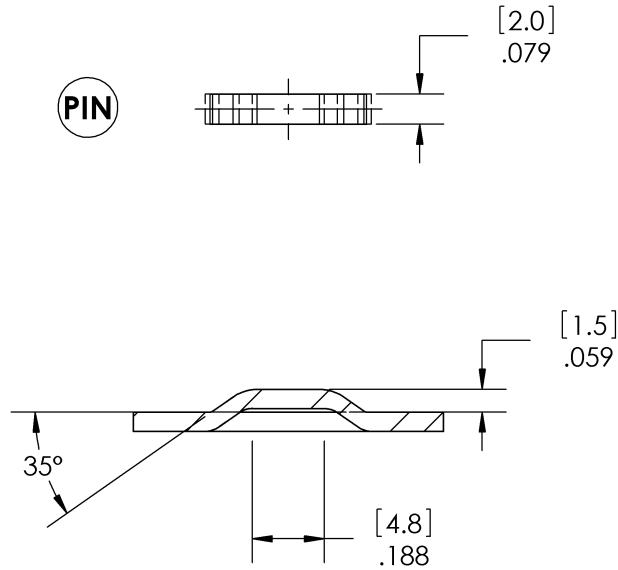

BSR
PROD# 9058482