



Acct# 1018326

Wilson Tool Intl. Plant
12912 Farnham Avenue
WHITE BEAR LAKE, MN 55110
US

Ship Via: UPS 2nd Day Air
SO: 1145147-30
Prod Ord: 8640840
P.O. Number 82011
Payment Terms Net due in 10 days

Sold To Triax Metal Products LLC
1880 SW Merlo Drive
CharBEAVERTON OR 97006
US

Ship To Triax Metal Products LLC
1880 SW Merlo Drive
BEAVERTON OR 97006
US

Contact: Shaun Fitch Phone: 503-649-9500 Fax: 503-649-1888 Email: shaun@triaxmetal.com

Order Date 04/03/2014	Target Ship Date 04/07/2014	Question Contact Damian Mendoza	Instructions
QTY: 1 2244 Thick Single Bridge Lance & Form Up B Station			
DWG 5807.STP			
STATION: B STATION (1-1/4)	RELIEF: NO RELIEF	KEYING: STANDARD	MATL: ALUMINUM
STYLE: DETERMINE	AUTO INDX: YES		MATL THK: 0.0250 in
MACHINE: AMADA	AL/HF: NO		MIN MATL: 0.0250 in
MODEL: VIPROS 358			COATING: NO COATING
Item 1 - FULL SET, CLR: 0.0040 in			

* THE APPROXIMATE ADJUSTED PUNCH LENGTH IS : 8.045

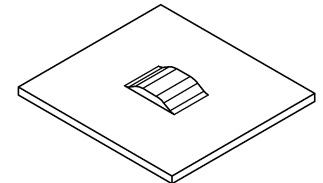
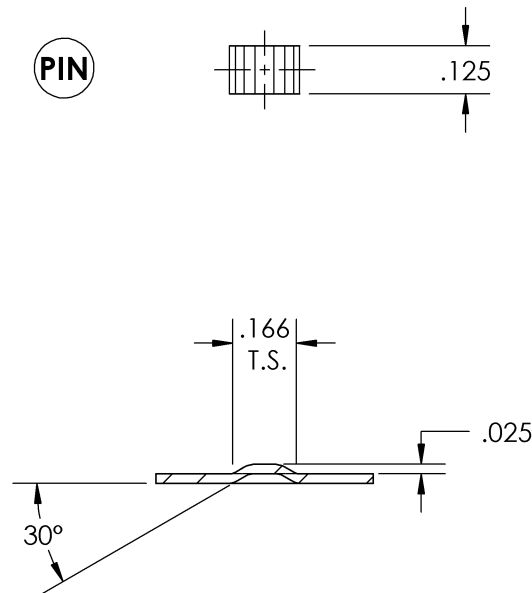

TCR
PROD# 8640840