



BIN NUMBER
0000-0

UPS SHIPPER NO. MN 5-65-685
SO: 263007-10

ACCOUNT NO. 0001018326

SOLD TO: Triax Metal Prod Inc
1880 SW Merlo Drive
BEAVERTON OR 97006
US

SHIP TO: Triax Metal Prod Inc
1880 SW Merlo Drive
BEAVERTON OR 97006
US

3571053

PROD. ORDER # 357-1053
QNC # 571053

P.O. NUMBER 58208
CUSTOMER Triax Metal Prod Inc

29

W.T. NUMBER 263007-10	ORDER DATE 11/18/2004	TARGET SHIP DATE 11/29/2004	CUSTOMER CONTACT Shaw n	CUSTOMER PHONE and FAX PH: 503-649-9500 FAX: 503-649-1888	QUESTIONS CONTACT Kirsten Erickson	TERMS WT10
SALES NO. A0024	INSTRUCTIONS			SHIP VIA UPS2		

**B STN THICK PROGRESSIVE RIB, FORM UP
PROGRESSIVE RIB TOOL .130 RADIUS C-.130 B-.260**

ITEM	QUANTITY	CLEARANCE	CATALOG NUMBER: 12651	SHAPE: SP
1	1			
FULL SET				
2	1			
LTD WTY SHEET DISTORTION				

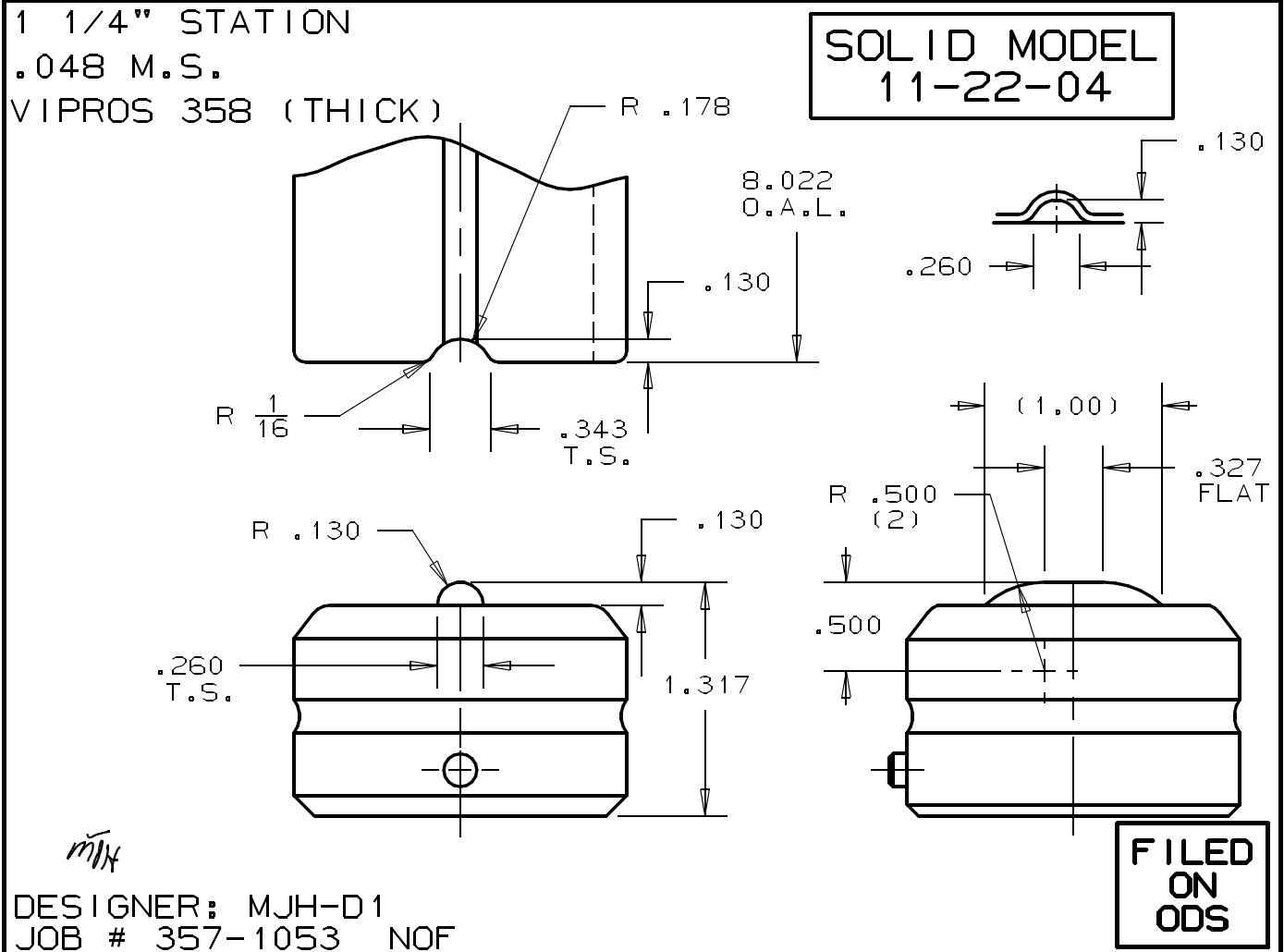

357-1053

**571053*
*571053000054100*11300844