

1 1/4" THICK ROUND CHIP TYPE EXTRUSION TOOL (STD.)

TOOL NUMBER	CUSTOMER NAME	DWG BY	DATE	MATERIAL INFO
PAEXT4011005	BEAVERTON PARTS MFG	STEVE	01/06/98	.048 CRS

Part # M 9794008-1

DUE DATE: 1-6-98

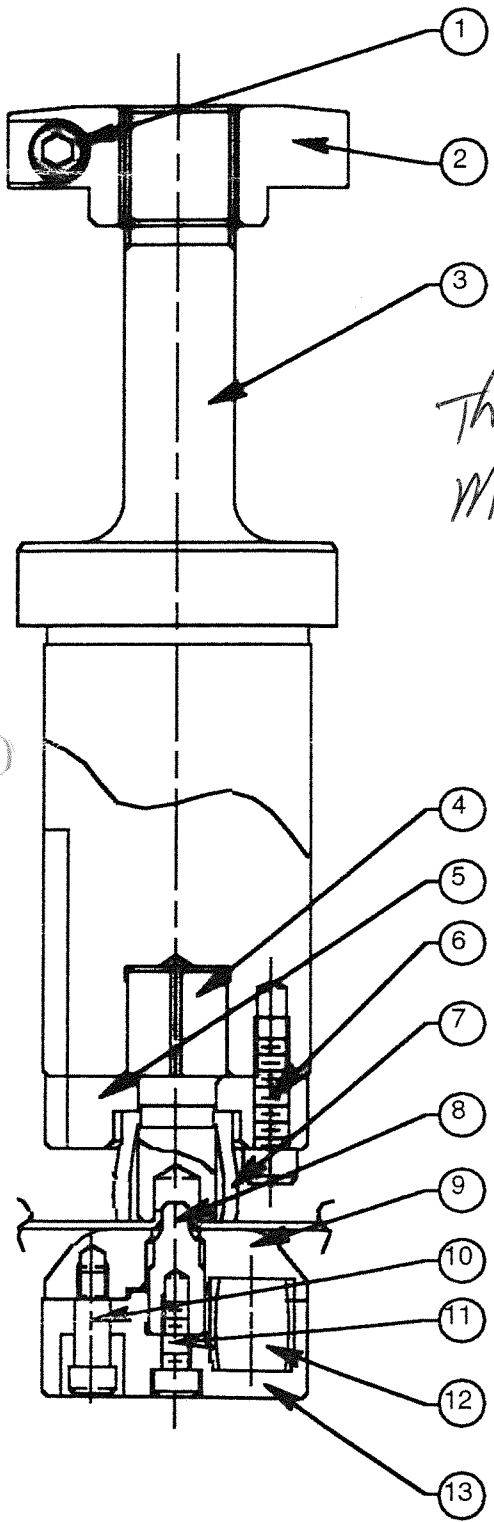

ØD .109

PREHOLE REQUIRED  
MAX. "H" = .118

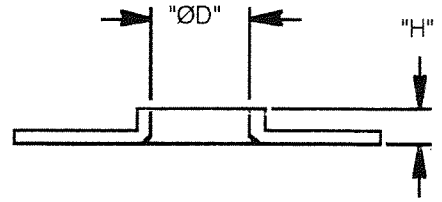

Thick Turret  
M3 UP Ø.109  
18 GA

QTY.	PART DESC.	PART NO.
1	SET	PAEXT401S
0	PUNCH ASS'Y	PAEXT401P
0	DIE ASS'Y	PAEXT401D

NO	PART NO.	ASSY QTY.		DESCRIPTION
		1	0	
PUNCH ASS'Y				
1	00106020	1	0	M6x20mm S.H.C.S
2	5523502P	1	0	PUNCH HEAD
3	5500201	1	0	PUNCH BODY (HOLDER)
4	5500202	1	0	PUNCH CHIP
5	5500203	1	0	PUNCH PLATE
6	00106020	4	0	M6x20mm S.H.C.S
7	5500204	1	0	URETHANE SPRING

NO	PART NO.	ASSY QTY.		DESCRIPTION
		1	0	
DIE ASS'Y				
8	9000181	1	1	DIE CHIP
9	5500206	1	0	EJECTOR PLATE
10	01006012	3	0	SHOULDER BOLT 6x12 (STO)
11	00105012	1	0	M5x12mm S.H.C.S.
12	01212025	3	0	Ø12x25mm URETHANE SPRING
13	5500221	1	0	DIE BLOCK