

1.1/4" THICK ROUND F/D EXTRUSION TOOLING

TOOL NUMBER	CUSTOMER NAME	DWG BY	DATE	MATERIAL INFO
A0004130854	TRIAX METAL	BDB	4/23/98	.075 CRS

ET# 98Q26531-1/2  
DUE DATE 4/24/98

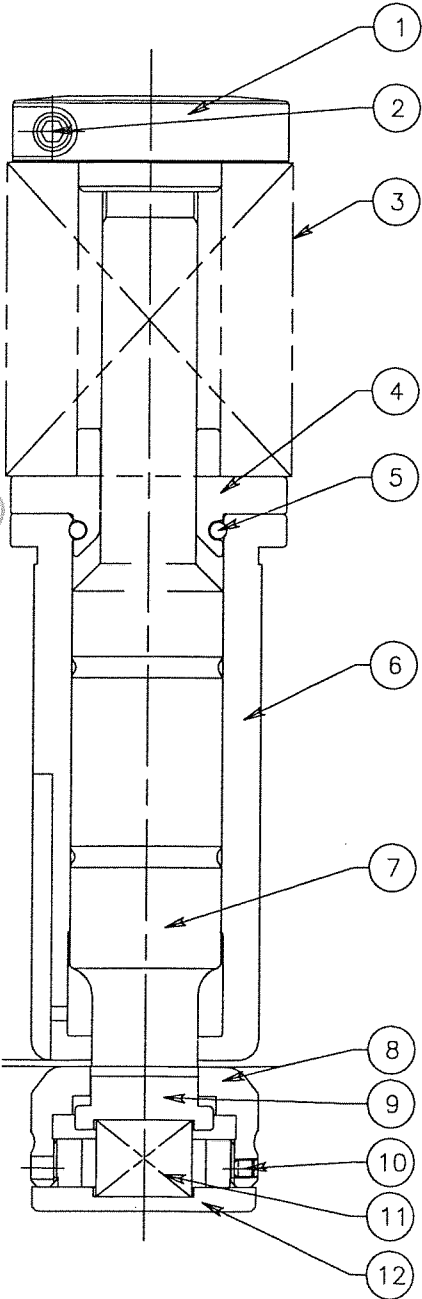
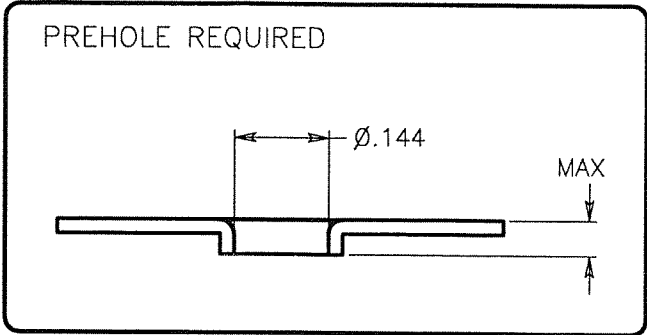

NO.	PART NUMBER	QTY	DESCRIPTION	SHEET #
1	5523502P		SINGLE PUNCH HEAD (STD)	
2	00106020		SHCS M6X20	
3	5500131		SPRING (STD)	
4	5500121		SPRING RETAINER (STD)	
5	91008K-90		O RING P26	
6	5500071		ROUND GUIDE (STD)	
7	5500031		ROUND PUNCH BODY (STD)	
8	5518009	1	DIE BODY	
9	9100208	1	DIE EJECTOR PIN	
10	00504004	1	SET SCREW M4X4	
11	01212020	1	URETHANE SPRING Ø12X20	
12	5552105	1	BACK UP PLATE	

Thick Turret  
M4 Down Ø.144  
14 GA

(lower unit only)