

1.1/4" THICK ROUND F/D EXTRUSION TOOLING

TOOL NUMBER	CUSTOMER NAME	DWG BY	DATE	MATERIAL INFO
A0004130814	TRIAx METAL	SM	1/8/98	.048 CRS

ET# 98M94008-3/4
DUE DATE 1/12/98

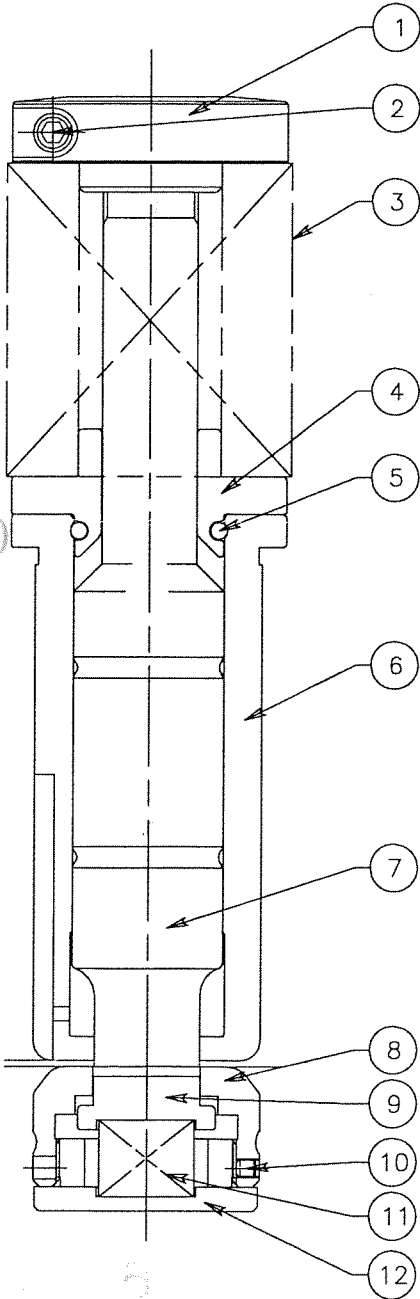
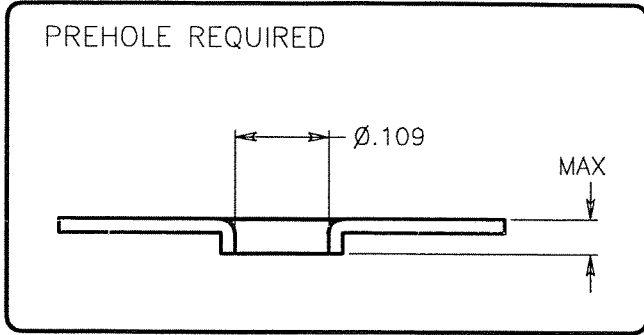

NO.	PART NUMBER	QTY	DESCRIPTION	SHEET #
1	5523502P	1	SINGLE PUNCH HEAD (STD)	
2	00106020	1	SHCS M6X20	
3	5500131	1	SPRING (STD)	
4	5500121	1	SPRING RETAINER (STD)	
5	91008K-90	1	O RING P26	
6	5500071	1	ROUND GUIDE (STD)	
7	5500031	2	ROUND PUNCH BODY (STD)	
8	5518009	1	DIE BODY	
9	9100208	1	DIE EJECTOR PIN	
10	00504004	1	SET SCREW M4X4	
11	01212020	1	URETHANE SPRING $\varnothing 12 \times 20$	
12	5552105	1	BACK UP PLATE	

Thick Turret
M3 Down $\varnothing.109$
18 GA