

ACCOUNT NO. 0001018326 SALES # 74862
 LINE # 10

SOLD TO Triax Metal Prod Inc
 1880 SW Merlo Drive
 BEAVERTON OR 97006
 US

SHIP TO Triax Metal Prod Inc
 1880 SW Merlo Drive
 BEAVERTON OR 97006
 US

17

P.O. NUMBER 53659
 CUSTOMER Triax Metal Prod Inc



W.T. NUMBER 2571420	ORDER DATE 12/10/2002	TARGET SHIP DATE 12/17/2002	CUSTOMER CONTACT SHAUN	CUSTOMER PHONE and FAX PH: 503-649-9500 FAX: 503-649-1888	QUESTIONS CONTACT WILLIAM ROTH	TERMS WT10
SALES NO. A0024	INSTRUCTIONS		SHIP VIA UPSG			

**B STN THICK FORM UP W/RELIEF
 EXTRUSION .090 DIA**

ITEM	QUANTITY	CLEARANCE	CATALOG NUMBER: 12561	SHAPE: SP
1	1			
FULL ASS'Y (SET)				

Assemble

M2.5 Form Tap

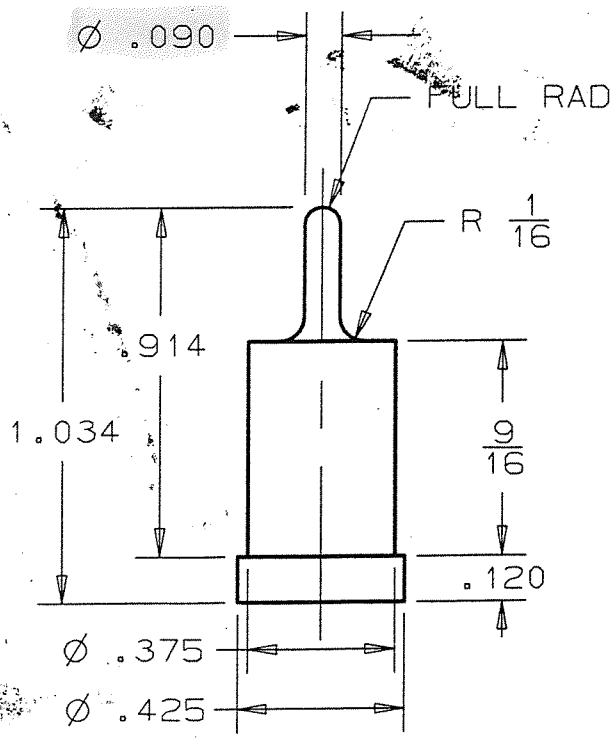

1 1/4" STATION
 UNIBODY UPPER UNIT
 NO OPTIMA
 3 SPRING DIE
 METRIC HARDWARE
 SLEEVE LENGTH: .422
 MATL: 18 GA (.048) M.S.
 MACH: PEGA 357 (THK)

EJECTOR TIP DIA: $\varnothing .146$
 DIE CAP : 00006-2
 -> OPENING: $\varnothing .135$
 -> WEB THICKNESS: .147
 APPROX. PREPUNCH:
 -> $\varnothing .048$ [1.2]
 OVERALL FORM HEIGHT: .096*
 *HEIGHT MAY BE UNATTAINABLE
 FILED

NO LENGTH TAG!!
 ADJUST UPPER UNIT TO 8.054

UNIBODY PUNCH TIP RELIEVED
 FOR .472 \varnothing to \varnothing
 (FILED)

DESIGNER: JNP-D1
 # 257-1420 NOF

2x SCALE

PACKING LIST