

Wilson Tool International

12912 Farnham Avenue
White Bear Lake, Minnesota 55110
Phone 1-800-328-9646

UPS SHIPPER NO. MN 5-65-685

PKG.I.D.# 202-7789

[827789]

ACCOUNT NO. 971231800 PPS NO. 716022

SOLD TO TRIAX METAL PROD INC
1880 SW MERLO DRIVE
BEAVERTON OR 97006
USA

SHIP TO TRIAX METAL PROD INC
1880 SW MERLO DRIVE
BEAVERTON OR 97006
USA

04



P.O. NUMBER 37705 30F3
CUSTOMER TRIAX METAL PROD INC

W.T. NUMBER 2027789	ORDER DATE 11/24/1998	TARGET SHIP DATE 12/04/1998	CUSTOMER CONTACT SHAWN FITCH	CUSTOMER PHONE NO. 503-649-9500	QUESTIONS CONTACT Doug Whorton	TERMS NET 10
------------------------	--------------------------	--------------------------------	---------------------------------	------------------------------------	-----------------------------------	-----------------

SALES NO. 24	INSTRUCTIONS	SHIP VIA UPS 2ND DAY PKG
-----------------	--------------	--------------------------

ITEM	QUANTITY	PART NO.	SHAPE	DIM1	DIM2	DIM3	CLEARANCE
1	1	02254	SP	0.000	0.000	0.000	0.000
THICK TURRET, 1 1/4 F/U EXTRUSION P & D ASSY FOR M-2 ROLL FORM LTD WTY							
2	1	02256	SP	0.000	0.000	0.000	0.000
THICK TURRET, 1 1/4 F/U EXTRUSION INSERT FOR ABOVE LTD WTY							

M2

SEND COMPLETE ASS'Y

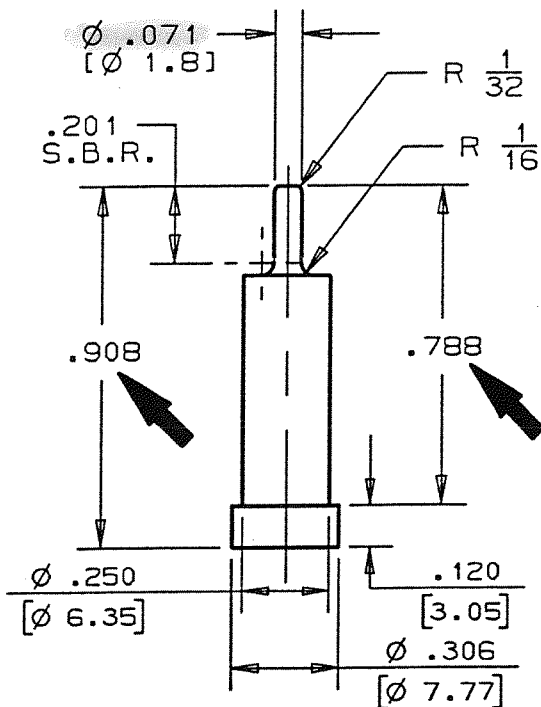

1 1/4" STATION
METRIC HARDWARE
OPTIMA COATING
ONE URETHANE
22 GA (.030) ST.ST.
VIPROS 358 (THICK)
PUNCH LENGTH: 8.040
PUNCH TIP: ϕ .800
PUNCH OPENING: ϕ .107
APPROX PRE-PUNCH: ϕ .046
OVERALL HEIGHT: .060
FILED

BRJ ODS

BOOKING COPY



827789000063150