

1.1/4" THICK EMBOSS A TYPE PUNCH CHIP / A TYPE DIE ASSY

TOOL NUMBER	CUSTOMER NAME	DWG BY	DATE	MATERIAL INFO
A10140103196	TRIAX METAL	SG	3/1/16	.051 AL

ET# 16812380
DUE DATE: 3/2/16

*SET P/ASSY LENGTH TO 8.040

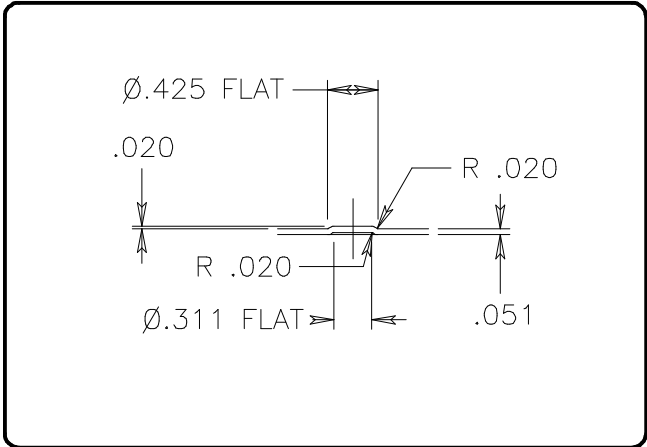
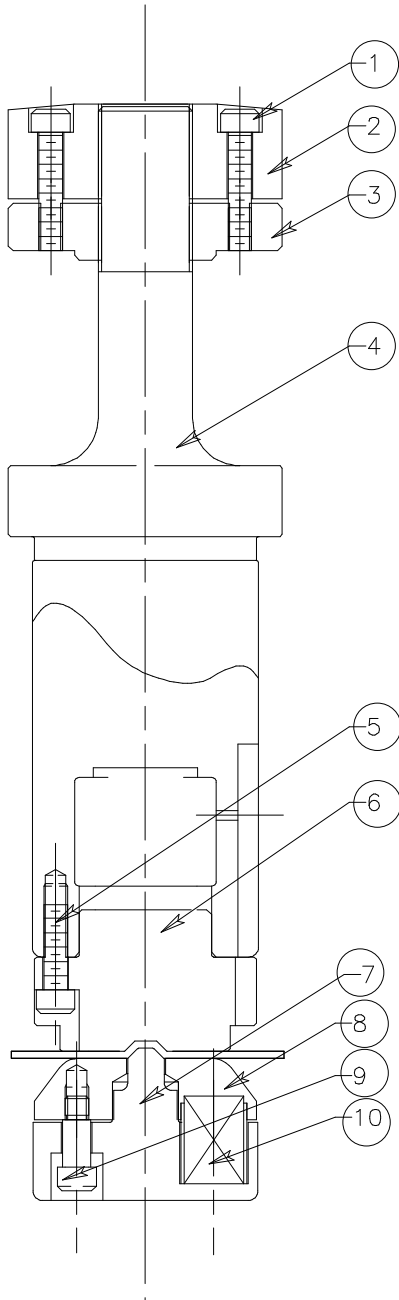

NO.	PART NUMBER	QTY	DESCRIPTION	SHEET #
1	00105025	4	M5X25 SHCS	
2	5518200	1	UPPER PUNCH HEAD 1	
3	5516431	1	LOWER PUNCH HEAD	
4	8700039	1	PUNCH HOLDER	
5	00105020	4	M5X20 SCHS	
6	8700048	1	PUNCH CHIP TYPE A	
7	8700042	1	DIE BODY TYPE A	
8	8700043	1	EJECTOR PLATE TYPE A	
9	01006010	3	STO 6X10	
10	01212025	3	URETHANE SPRING $\text{Ø}12 \times 25$	