

Wilson Tool International

12912 Farnham Avenue
White Bear Lake, Minnesota 55110
Phone 1-800-326-9448

UPS SHIPPER NO. MN 6-65-685
PKG.I.D.# 206-3628
(863628)

ACCOUNT NO. 971231800 PPS NO. 834354

TRIAx METAL PROD INC
1880 SW MERLO DRIVE
BEAVERTON OR 97008
USA

SHIP TRIAX METAL PROD INC
TO 1880 SW MERLO DRIVE
BEAVERTON OR 97008
USA

P.O. NUMBER 41520
CUSTOMER TRIAX METAL PROD INC

W.T. NUMBER	ORDER DATE	TARGET SHIP DATE	CUSTOMER CONTACT	CUSTOMER PHONE NO.	QUESTIONS CONTACT	TERMS
2063628	09/20/1999	09/30/1999	SHAWN FITCH	503-649-9500	Lyle Pohlen	NET 10

SALES NO.	INSTRUCTIONS	SHIP VIA
24		UPS 2ND DAY PKG

ITEM	QUANTITY	PART NO.	SHAPE	DIM1	DIM2	DIM3	CLEARANCE
1	1	02509	SP	0.000	0.000	0.000	0.000
THK TURRET, 1-1/4 RD F/D ONLY P&G ASSY AND DIE EMBOSS .300 DIA							
2	1	06121		0.000	0.000	0.000	0.000
WILSON TOOL NOT RESPONSIBLE FOR SHEET DISTORTION							

Acknowledgement Copy

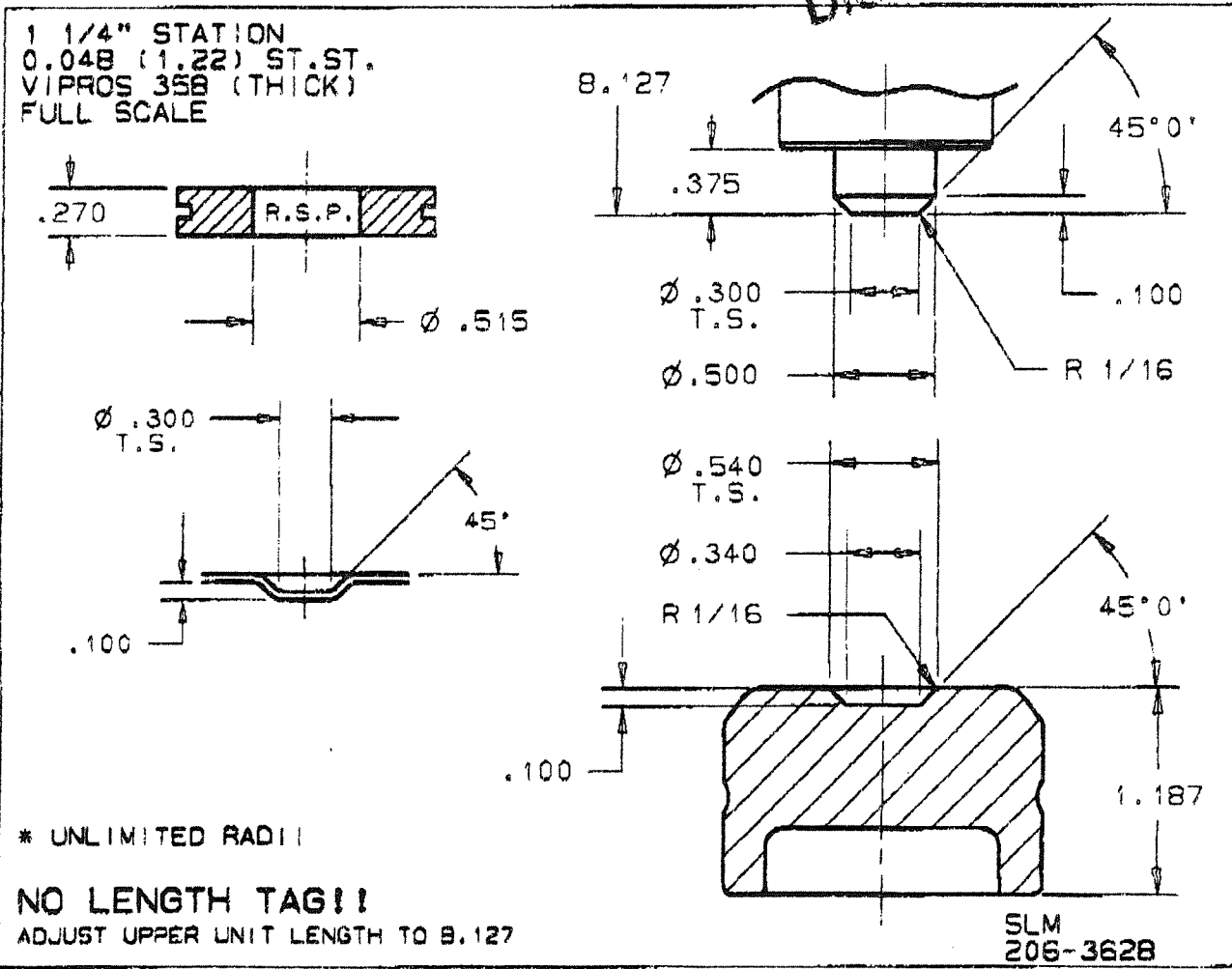

UNIT TOOL DESIGN WORKSHEET 661 62 435