

Wilson Tool International

12912 Farnham Avenue
White Bear Lake, Minnesota 55110
Phone 1-800-328-8648

P. 1
UPS SHIPPER NO. MN 5-65-685
PKG.I.D.# 201-2645
(812645)

ACCOUNT NO. 971231800 PPS NO. 883899

TRIAx METAL PROD INC
1880 SW MERLO DRIVE
BEAVERTON OR 97006
USA

SHIP TRIAX METAL PROD INC
TO 1880 SW MERLO DRIVE
BEAVERTON OR 97006
USA

P.O. NUMBER 35930 10F2

CUSTOMER TRIAX METAL PROD INC

W.T. NUMBER 2012645	ORDER DATE 07/15/1998	TARGET SHIP DATE 07/27/1998	CUSTOMER CONTACT SHAWN FITCH	CUSTOMER PHONE NO. 503-649-9500	QUESTIONS CONTACT Doug Whorton	TERMS NET 10	
SALES NO. 24	INSTRUCTIONS		SHIP VIA UPS NDA SAT DEL				
ITEM	QUANTITY	PART NO.	SHAPE	DIM1	DIM2	DIM3	CLEARANCE
1	1	02509	SP	0.000	0.000	0.000	0.000
THK TURRET, 1-1/4 RD F/D ONLY P&G ASSY AND DIE EMBOSS .800 DIA							
2	1	06121		0.000	0.000	0.000	0.000
WILSON TOOL NOT RESPONSIBLE FOR SHEET DISTORTION							

1 1/4" STATION
0.125 (3.18) ALUM.
VIPROS 357 (THK)
FULL SCALE

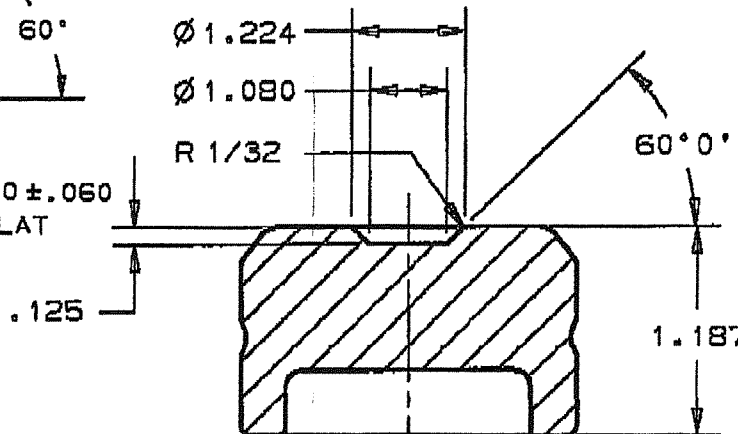
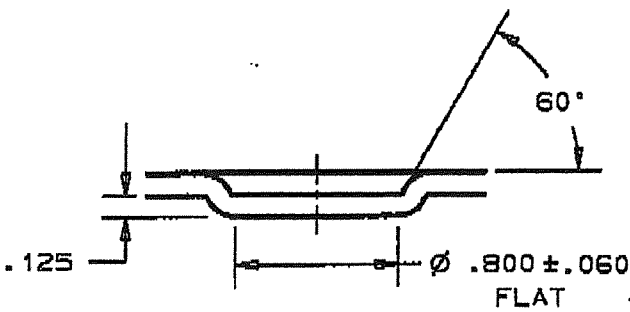
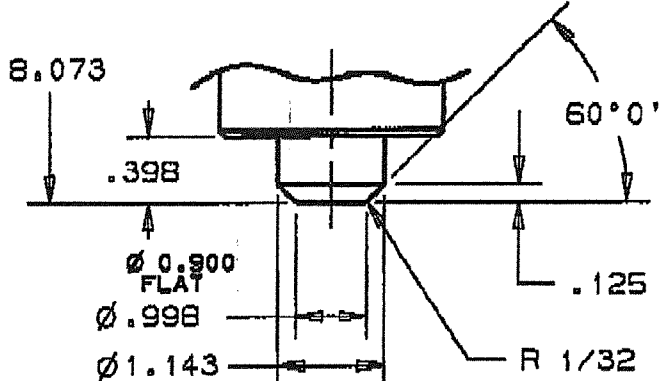
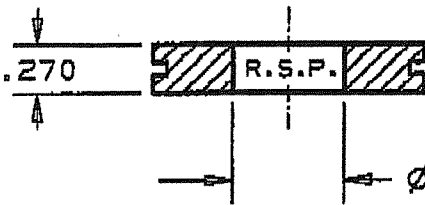

NO LENGTH TAG!!
ADJUST UPPER UNIT LENGTH TO 8.073

CG
2012645

Acknowledgement Copy